



HY2212

Data Sheet

1 Cell Li-ion/Polymer Battery Charge Balance IC

Table of Contents

1. GENERAL DESCRIPTION	4
2. FEATURES	4
3. APPLICATIONS	4
4. BLOCK DIAGRAM.....	5
5. ORDERING INFORMATION	5
6. MODEL LIST.....	6
6.1. Product Name List.....	6
6.2. Characteristic Code—Other Function Options	6
7. PIN CONFIGURATION AND PACKAGE MARKING INFORMATION	6
8. ELECTRICAL CHARACTERISTICS	7
8.1. Absolute Maximum Ratings	7
8.2. Electrical Parameters (Except Delay time)	7
9. EXAMPLE CIRCUIT OF BATTERY CHARGE BALANCE IC APPLICATION.....	8
10. DESCRIPTION OF OPERATION.....	9
10.1. Normal Status.....	9
10.2. Overcharge Status	9
10.3. Standby Status	9
11. CHARACTERISTICS (TYPICAL DATA).....	10
12. PACKAGE INFORMATION.....	11
12.1. SOT-23-6 Package.....	11
13. TAPE & REEL INFORMATION.....	12
13.1. Tape & Reel Information ---SOT-23-6 (Type 1).....	12
13.2. Tape & Reel Information ---SOT-23-6 (Type 2).....	13
14. REVISION RECORD.....	14

Attention :

1. HYCON Technology Corp. reserves the right to change the content of this datasheet without further notice. For most up-to-date information, please constantly visit our website:
<http://www.hycontek.com> .
2. HYCON Technology Corp. is not responsible for problems caused by figures or application circuits narrated herein whose related industrial properties belong to third parties.
3. Specifications of any HYCON Technology Corp. products detailed or contained herein stipulate the performance, characteristics, and functions of the specified products in the independent state. We does not guarantee of the performance, characteristics, and functions of the specified products as placed in the customer's products or equipment. Constant and sufficient verification and evaluation is highly advised.
4. Please note the operating conditions of input voltage, output voltage and load current and ensure the IC internal power consumption does not exceed that of package tolerance. HYCON Technology Corp. assumes no responsibility for equipment failures that resulted from using products at values that exceed, even momentarily, rated values listed in products specifications of HYCON products specified herein.
5. Notwithstanding this product has built-in ESD protection circuit, please do not exert excessive static electricity to protection circuit.
6. Products specified or contained herein cannot be employed in applications which require extremely high levels of reliability, such as device or equipment affecting the human body, health/medical equipments, security systems, or any apparatus installed in aircrafts and other vehicles.
7. Despite the fact that HYCON Technology Corp. endeavors to enhance product quality as well as reliability in every possible way, failure or malfunction of semiconductor products may happen. Hence, users are strongly recommended to comply with safety design including redundancy and fire-precaution equipments to prevent any accidents and fires that may follow.
8. Use of the information described herein for other purposes and/or reproduction or copying without the permission of HYCON Technology Corp. is strictly prohibited.

1. General Description

The series of HY2212 is created for multi-cell battery packs to single-cell lithium-ion battery Charge balance control, electrical level monitoring ICs and it also comprises high-accuracy voltage detection circuit and delay circuit.

2. Features

The HY2212 series IC is provided with the following characteristics:

(1) High-accuracy voltage detection circuit.

- Overcharge detection voltage 3.200~4.000V Accuracy: $\pm 25\text{mV}$
- Overcharge release voltage 3.000~4.000V Accuracy: $\pm 35\text{mV}$
- Standby detection voltage 2.70V Accuracy: $\pm 15\%$
- Standby release voltage 2.70V Accuracy: $\pm 15\%$

(2) Delay times are generated by an internal circuit (external capacitors are unnecessary).

(3) Low current consumption (Standby Status).

- Operation mode Typical 2.5 μA , Max 3.5 μA (VDD=3.2V)
- Ultra low power-down current at Max 0.5 μA (VDD=2.0V)

(4) Wide operating temperature range -40°C to $+85^{\circ}\text{C}$

(5) Small Package: SOT-23-6

(6) The HY2212 series are Halogen-free, green package

3. Applications

- Multi Cells LiFePO4 Rechargeable Battery Packs.

4. Block Diagram

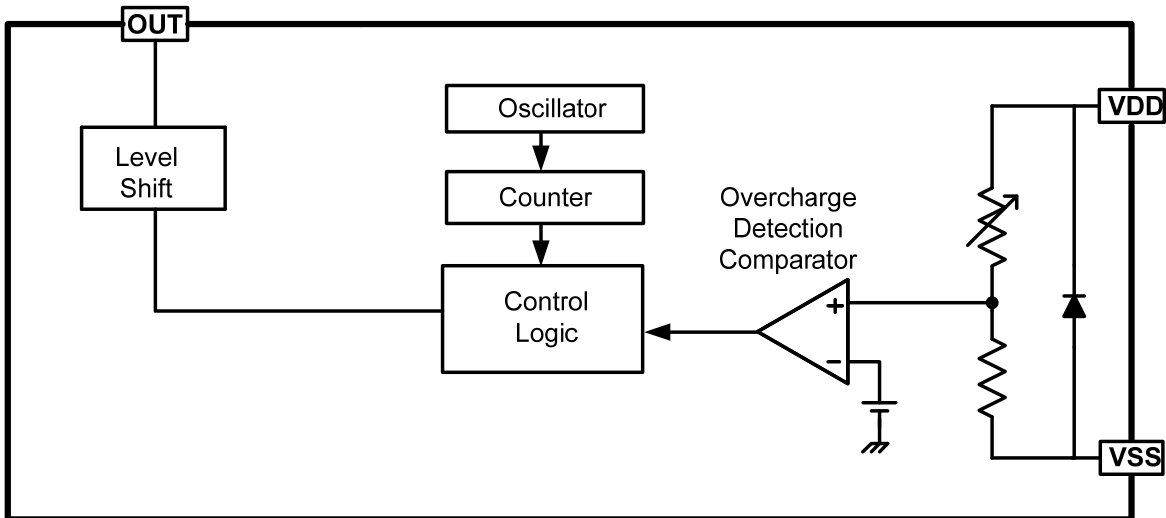

5. Ordering Information

- Product Name define

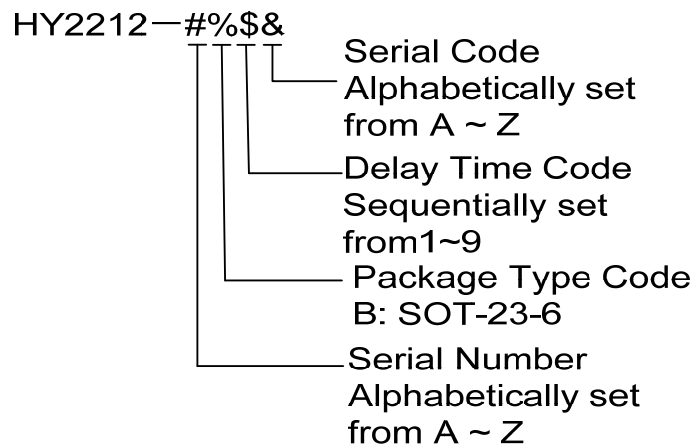

6. Model List

6.1. Product Name List

- SOT-23-6 Package

Table 1 Model list for SOT-23-6

Parameters Model	Overcharge Detection Voltage	Overcharge Release Voltage	Delay Time Code	Characteristic Code
	V _{CU}	V _{CR}	-	-
HY2212-AB3B	3.600±0.025V	3.600±0.035V	3	B
HY2212-BB3A	3.600±0.025V	3.590±0.035V	3	A

Remark :

1. Table 1 lists various electrical parameters typical value, See Table 5 for each electrical parameter accuracy.
2. See Table 3 for other features characteristic code corresponding.
3. Please contact our sales office for the products with detection voltage value other than those specified above.

6.2. Characteristic Code—Other Function Options

Table 2 Characteristic Code-Other Function Options

Characteristic Code	Out Effective Operation
A	N-MOSFET balance control; OUT output status L→H effective
B	P-MOSFET balance control; OUT output status H→L effective

7. Pin Configuration and Package Marking Information

- SOT-23-6 Package

Table 3 SOT-23-6 Package

PIN	Symbol	Description
1	NC	No connection
2	VDD	Power end, positive power input pin
3	VSS	Grounding end, negative power input pin
4	NC	No connection
5	NC	No connection
6	OUT	Charge balance, Control MOSFET gate and connection pin

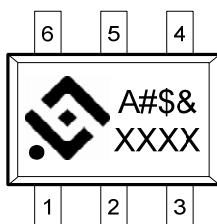

A: Product Name Code.

#: Serial Number, Alphabetically set by A~Z.

\$: Delay Time code, Sequentially set from 1~9.

&: Characteristics Code, Alphabetically set From A~Z.

XXXX: Date Code.

8. Electrical Characteristics

8.1. Absolute Maximum Ratings

Table 4 Absolute Maximum Ratings (VSS=0V, Ta=25°C, unless otherwise specified)

Item	Symbol	Specification	Unit
Input voltage between VDD and VSS pin	V _{DD}	VSS-0.3~VSS+10	V
OUT Output pin voltage	V _{OC}	VSS-0.3~VDD+0.3	V
Operating Temperature Range	T _{OP}	-40~+85	°C
Storage Temperature Range	T _{ST}	-40~+125	°C
Power dissipation	P _D	250	mW

8.2. Electrical Parameters (Except Delay time)

Table 5 Electrical Parameters (Except Delay time. VSS=0V, Ta=25°C, unless otherwise specified)

Item	Symbol	Condition	Min.	Typ.	Max.	Unit
INPUT VOLTAGE/ Current Consumption.						
Operating voltage between VDD pin and VSS pin	V _{DSOP1}	-	1.5	-	8	V
Supply Current	I _{DD}	V _{DD} =3.2V	-	2.5	3.5	μA
Standby Current	I _{SB}	V _{DD} =2.0V	-	0.15	0.5	μA
DETECTION VOLTAGE						
Overcharge Detection Voltage	V _{CU}	3.2~4.0V, Adjustable	V _{CU} -0.025	V _{CU}	V _{CU} +0.025	V
		3.2~4.0V, Adjustable -5°C~55°C (*1)	V _{CU} -0.035	V _{CU}	V _{CU} +0.035	V
Overcharge Release Voltage	V _{CR}	3.0~4.0V, Adjustable	V _{CR} ≠V _{CU}	V _{CR}	V _{CR} +0.035	V
			V _{CR} =V _{CU}	V _{CR} -0.035	V _{CR}	V _{CR} +0.025
Standby Detection Voltage	V _{SB}	2.0~3.0V, Adjustable	2.3	2.7	3.1	V
Delay Time						
Overcharge Detection Delay Time	T _{OC}	V _{DD} =3.2V→4.5V	200	250	300	ms
CONTROL PIN OUTPUT VOLTAGE						
OUT PIN output High voltage	V _{OUT_H}		VDD-0.1	VDD-0.02	-	V
OUT PIN output Low voltage	V _{OUT_L}		-	0.1	0.5	V

Description: (*1) Since product are not screened by high or low temperature, the specification for this temperature is guaranteed by design. Not test in product.

9. Example Circuit of Battery Charge Balance IC Application

Example application of HY2212-xxxA using N-MOSFET of charge balance

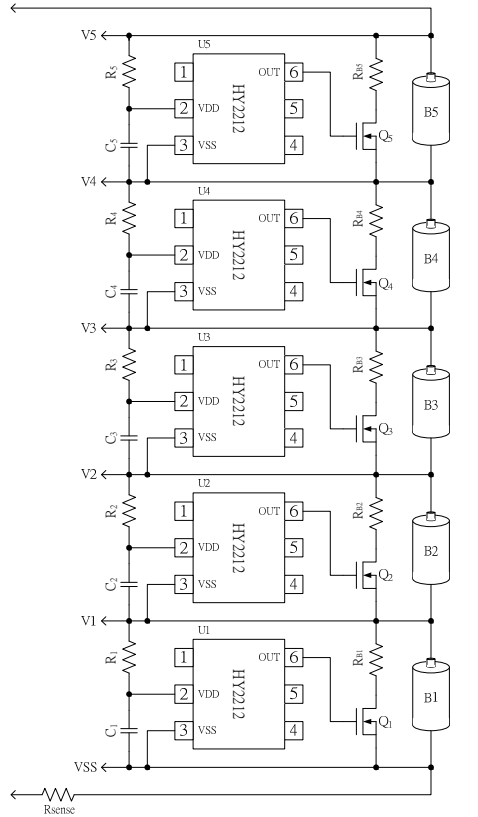

Example application of HY2212-xxxA using P-MOSFET of charge balance

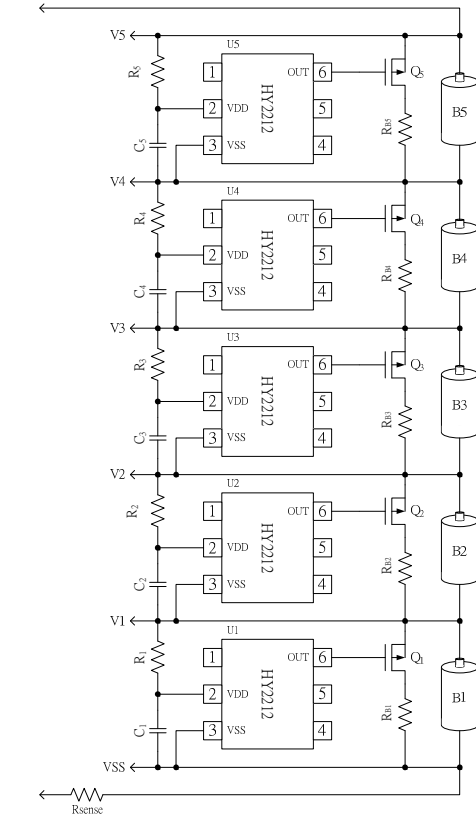

Symbol	Device Name	Purpose	Min.	Typ.	Max.	Remark
R1-5	Resistor	Limit current, stabilize VDD and strengthen ESD protection	100Ω	100Ω	200Ω	*1
R _{B1-5}	Resistor	Charge balance release load				*2
C1-5	Capacitor	Filtering, stable VDD	0.01μF	0.1μF	1.0μF	*3
Q1-5	N-MOSFET	Charge balance control	-	-	-	*4

- *1. If R1-5 connects with an over-spec resistor, battery accuracy may be influenced due to current consumption cause R1 voltage drops. When a charger is connected in reversed, the current flows from the charger to the IC. At this time, if R1 is too high, the voltage between VDD pin and VSS pin may exceed the absolute maximum rating.
- *2. R_{B1-5} connects with an under-spec resistor, when battery voltage exceed Overcharge Detection Voltage (V_{CU}) will let charge current suddenly become large, which may result in charge overcurrent phenomenon which allows circuit system be protected and can not be charged.
- *3. C1-5 can stabilize the supply voltage of VDD, Do not connect capacitor that under 0.01μF.
- *4. To select N-MOSFET or P-MOSFET, depends on the product type.

Caution:

1. The above constants may be changed without notice, please download the most up-to-date datasheet on our website. <http://www.hycontek.com>
2. It is advised to perform thorough evaluation and test if peripheral devices need to be amended.

10. Description of Operation

10.1. Normal Status

This IC continuously monitors the voltage of the battery connected between the VDD and VSS, to control charge and discharge. When battery voltage exceed overcharge detection voltage (V_{CU}), OUT pin output electrical level will change from high to low to control P-MOSFET or OUT pin electrical level change from low to high to control N-MOSFET; or the voltage of the battery cell lower than the overcharge release voltage (V_{CR}), OUT pin output electrical level change from low to high to control P-MOSFET or OUT pin output electrical level change from high to low to control N-MOSFET to turn off. This status is called “Normal status” Which also can freely operate while charging.

10.2. Overcharge Status

Under the normal status, as soon as the battery voltage becomes higher than the overcharge detection voltage (V_{CU}) during charge and the detection time continues longer than the overcharge detection delay time (TOC); or the voltage of the battery voltage lower than the overcharge release voltage (V_{CR}), HY2212 Series IC will turn the MOSFET (OUT pin) on or off, this condition is called the “Overcharge status” or “Charge balance control” .

Overcharge status has following two options turning charge control balance MOSFET on and off :

(1) Selection of HY2212-xxxA series, using the N-MOSFET as the charge balance control

(a) During charging process, the battery voltage becomes higher than the overcharge detection voltage (V_{CU}) and the detection time continues longer than the overcharge detection delay time (TOC), OUT pin will produce L→H to turn on N-MOSFET.

(b) During charging process, the battery voltage is lower than the overcharge release voltage (V_{CR}), OUT pin produces H→L to turn off the N-MOSFET.

(2) Selection of HY2212-xxxB series, using P-MOSFET as the charge balance control.

(a) During charging process, the battery voltage becomes higher than the overcharge detection voltage (V_{CU}) and the detection time continues longer than the overcharge detection delay time (TOC), OUT pin will produce H →L to turn on P-MOSFET.

(b) During charging process, the battery voltage is lower than the overcharge release voltage measurement (V_{CR}), OUT pin produces L→H to turn off the P-MOSFET.

10.3. Standby Status

Under normal status, During discharge process, when battery voltage drops lower than Standby Detection voltage (V_{SB}), IC current consumption minimize to standby status current consumption value, this status is called “Standby Status” .

11. Characteristics (Typical Data)

1. Overcharge Detection/Release Voltage and Delay Time

(1) V_{CU} vs. T_a

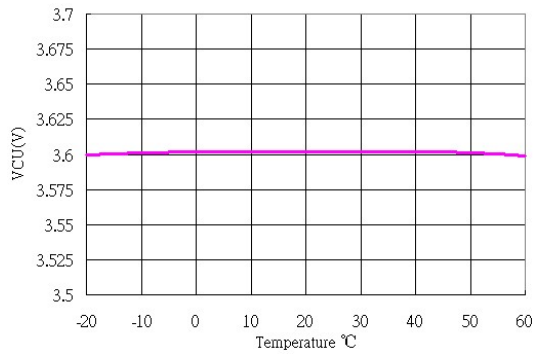

(2) V_{CR} vs. T_a

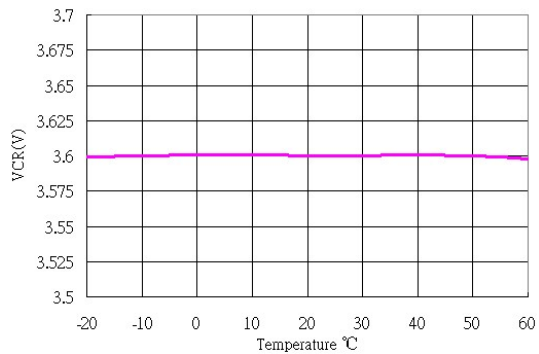

(3) T_{OC} vs. T_a

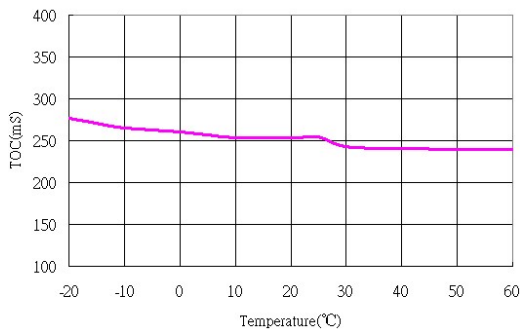

2. Current Consumption

(4) I_{DD} vs. T_a

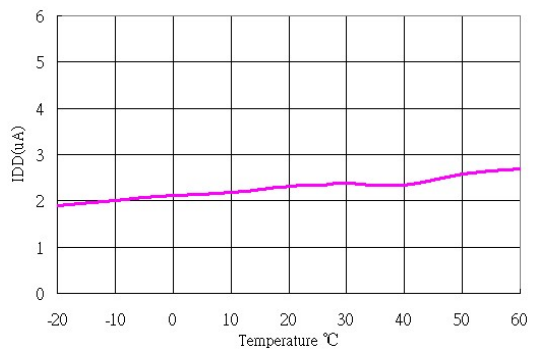

12. Package Information

12.1. SOT-23-6 Package

Description : Unit (mm.)

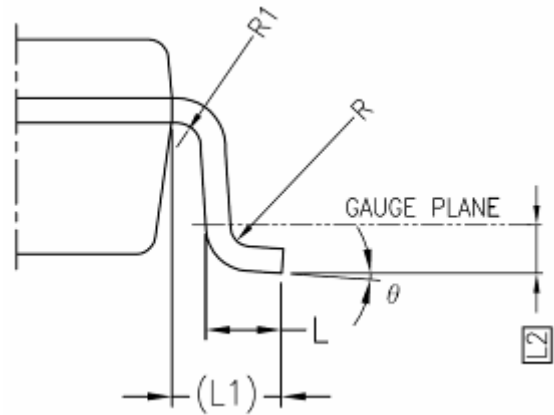
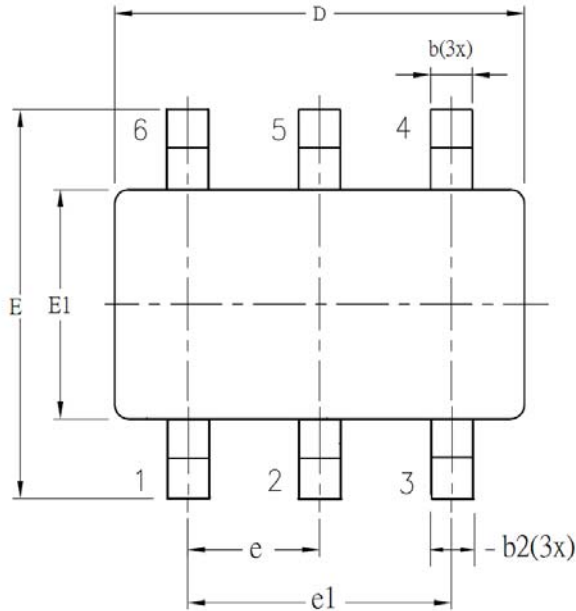

SYM BOL	ALL DIMENSIONS IN MILLIMETERS		
	MINIMUM	NOMINAL	MAXIMUM
A	-	1.30	1.40
A1	0	-	0.15
A2	0.90	1.20	1.30
b	0.30	-	0.50
b1	0.30	0.40	0.45
b2	0.30	0.40	0.50
c	0.08	-	0.22
c1	0.08	0.13	0.20
D	2.90 BSC		
E	2.80 BSC		
E1	1.60 BSC		
e	0.95 BSC		
e1	1.90 BSC		
L	0.30	0.45	0.60
L1	0.60 REF		
L2	0.25 BSC		
R	0.10	-	-
R1	0.10	-	0.25
theta	0°	4°	8°
theta1	5°	-	15°
theta2	5°	-	15°

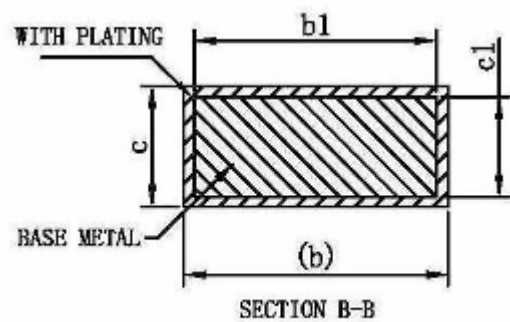
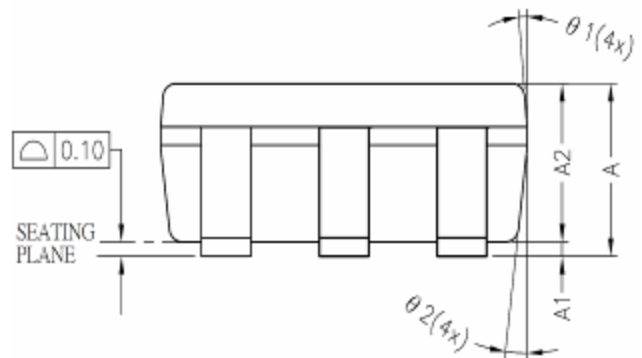

13. Tape & Reel Information

13.1. Tape & Reel Information ---SOT-23-6 (Type 1)

Description: Unit: mm.

13.1.1 Reel Dimensions

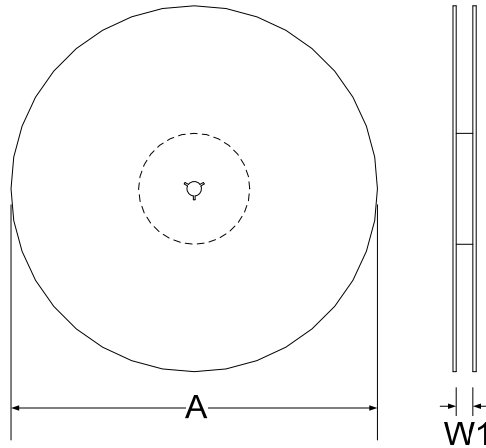

13.1.2 Carrier Tape Dimensions

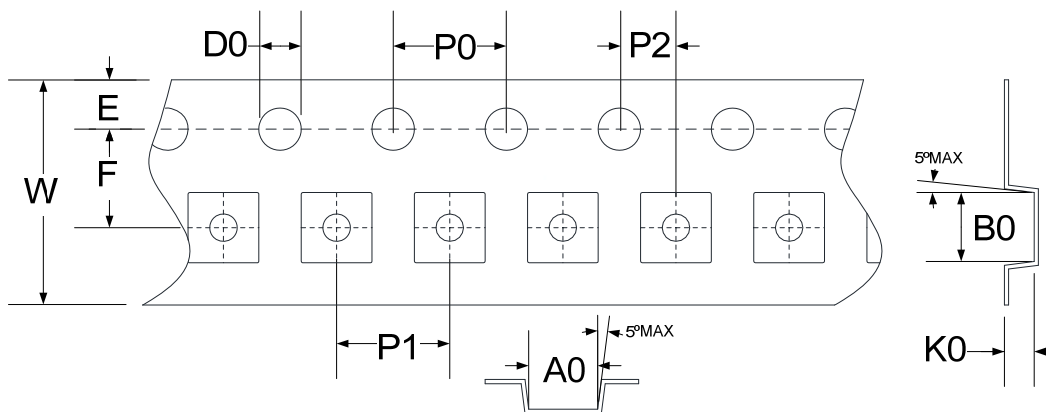

SYMBOLS	Reel Dimensions		Carrier Tape Dimensions											
	A	W1	A0	B0	K0	P0	P1	P2	E	F	D0	W		
Spec.	178	9.0	3.30	3.20	1.50	4.00	4.00	2.00	1.75	3.50	1.50	8.00		
Tolerance	±0.50	+1.50/-0	±0.10	±0.10	±0.10	±0.10	±0.10	±0.10	±0.10	±0.05	±0.10	±0.05	+0.1/-0	±0.20

Note: 10 Sprocket hole pitch cumulative tolerance is ±0.20mm.

13.1.3 Pin1 direction

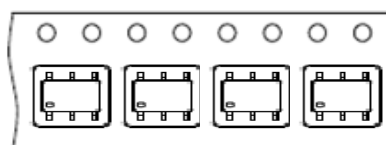

13.2. Tape & Reel Information ---SOT-23-6 (Type 2)

Description: Unit: mm.

13.2.1 Reel Dimensions

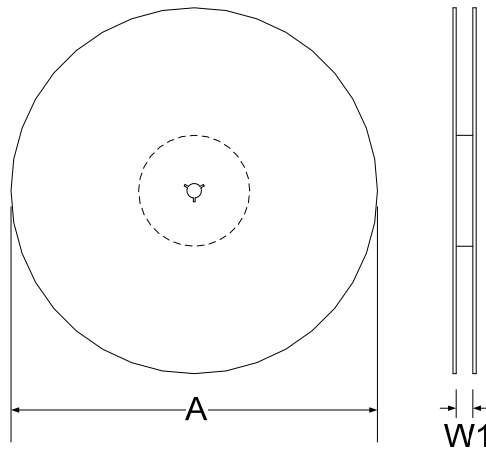

13.2.2 Carrier Tape Dimensions

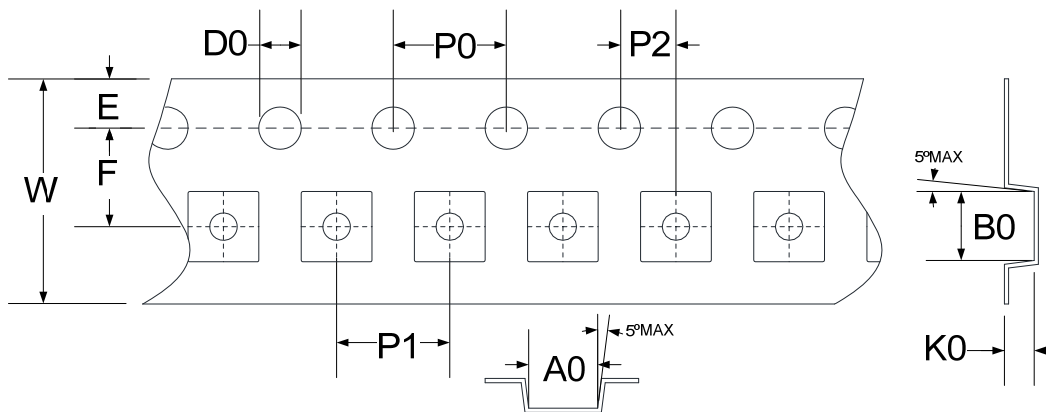

SYMBOLS	Reel Dimensions		Carrier Tape Dimensions									
	A	W1	A0	B0	K0	P0	P1	P2	E	F	D0	W
Spec.	178	9.4	3.17	3.23	1.37	4.00	4.00	2.00	1.75	3.50	1.55	8.00
Tolerance	± 2.00	± 1.50	± 0.10	± 0.10	± 0.10	± 0.10	± 0.10	± 0.05	± 0.10	± 0.05	± 0.05	$+0.30/-0.10$

Note: 10 Sprocket hole pitch cumulative tolerance is $\pm 0.20\text{mm}$.

13.2.3 Pin1 direction

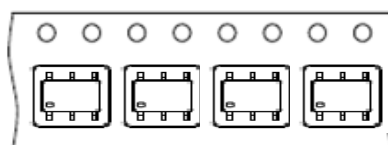

14. Revision Record

Major differences are thereafter

Version	Page	Revision Summary
V01	-	First Edition.
V02	All	Electrical parameters Modifications.
V03	All	Add Tape & Reel Information.
V04	8	Revise picture of Example Circuit of Battery Charge Balance IC Application.